



Colour TFT Display Module

Product Specification
Part No. SCX1001XXXGGU33
10.1" WXGA IPS Display

For more information, please visit www.andersdx.com
or email info@andersdx.com

Version 2

DATA IMAGE CORPORATION

CTP Module Specification Preliminary

ITEM NO.: SCX1001XXXGGU33

Table of Contents

1. COVER & CONTENTS	1
2. RECORD OF REVISION	2
3. GENERAL SPECIFICATIONS	3
4. LCD ABSOLUTE MAXIMUM RATINGS.....	3
5. LCD ELECTRICAL CHARACTERISTICS	3
6. LCD PIN CONNECTIONS	7
7. LCD BLOCK DIAGRAM.....	8
8. CTP GENERAL SPECIFICATIONS	9
9. OPTICAL CHARACTERISTIC	10
10. QUALITY ASSURANCE	13
11. LCM PRODUCT LABEL DEFINE	17
12. PRECAUTIONS IN USE LCM	19
13. OUTLINE DRAWING	20
14. PACKAGE INFORMATION	21

Customer Companies	QA Approved	DQA Check	R&D Approved	R&D Check
	<i>Beth</i>	<i>Huong</i>	<i>Alex</i>	<i>Nomo</i>
Customer Approved by	Version:	Issued Date:	Total Pages:	Prepared
	2	15/JAN/16'	21	<i>Rudy</i>

3. GENERAL SPECIFICATIONS

Composition: A touch panel module with 10.1 inches Capacitive Touch Panel (CTP) .

Interface:USB for the CTP.

Parameter	Specifications	Unit
Screen size	10.1(Diagonal)	inch
Display resolution	1,280(H) x (R,G,B) x 800(V)	dot
LCD active area	216.96(H)x135.6(V)	mm
Sensor active area	218.96(W) x 137.6(H)	mm
Outline Dimension	253.9(W) x 170.7(H) x 8.6(D)	mm
Dot pitch	0.0565(H)x0.1695(V)	mm
Color configuration	R.G.B. Stripe	
Display Mode	Normally Black, Transmissive	
View Angle direction	All	
LCD Part Number	FX1001F5DSSWNG01	
Our components and processes are compliant to RoHS standard		

4. LCD ABSOLUTE MAXIMUM RATINGS

Item	Symbol	Min	Max	Unit	Remark
Power Voltage	VDD	-0.3	5	V	
	LED_VCCS	-0.3	6.5	V	
Operating temperature	Top	0	50	°C	
Storage temperature	Tst	-20	60	°C	

Note 1: The absolute maximum rating values of this product are not allowed to be exceeded at any times. Should a module be used with any of the absolute maximum ratings exceeded, the characteristics of the module may not be recovered, or in an extreme case, the module may be permanently destroyed.

5. LCD ELECTRICAL CHARACTERISTICS

5.1 Typical Operation Conditions

(GND=0V, Ta=25°C)

Item	Symbol	Values			Unit	Remark
		Min.	Typ.	Max.		
Power voltage	VDD	3.0	3.3	3.6	V	
	LED_VCCS	4.8	5.0	6.2	V	
Internal VCOM voltage	VCOM		3.0		V	
Input logic high voltage	VIH	2.0	-	3.6	V	
Input logic low voltage	VIL	0	-	0.5	V	
Current for Driver	IVDD	-	-	350	mA	VDD=3.3V
	ILED_VCCS	-	600	900	mA	LED_VCCS=5V,Duty=100%
PWM Control Level	PWM High Level	3.0	-	3.6	V	
	PWM Low Level	0	-	0.4	V	
PWM Control Frequency	fPWM	1K	-	20K	Hz	
LED life time		30,000	-	-	Hr	Note1

Note1 : The "LED life time" is defined as the module brightness decrease to 50% original brightness at Ta=25°C and LED_PWM=100% duty.

5.2 Power Sequence

a. Power on:

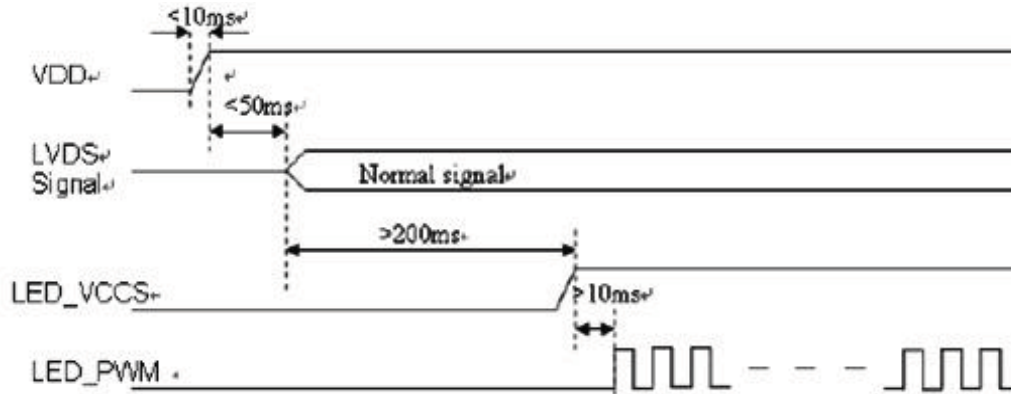

b. Power off:

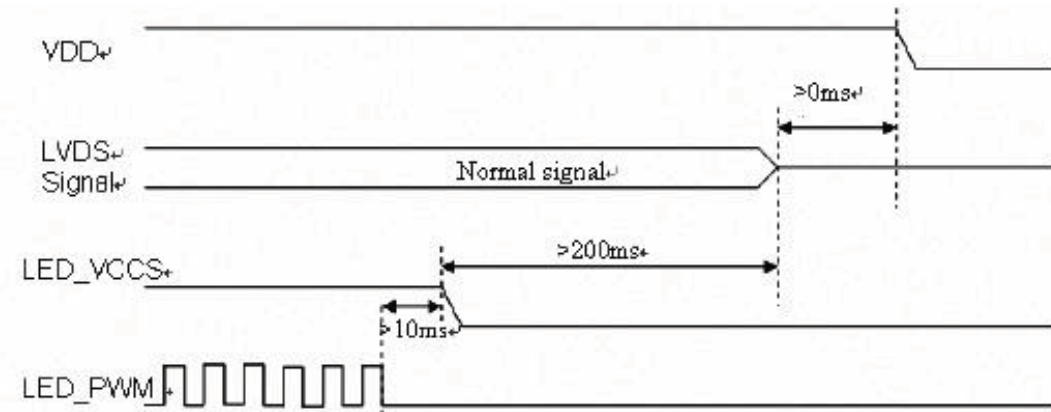

5.3 LVDS Signal Timing Characteristics

5.3.1 AC Electrical Characteristics

Parameter	Symbol	Values			Unit	Remark
		Min.	Typ.	Max.		
LVDS Differential input high Threshold voltage	RXVTH	-	-	+100	mV	RXVCM=1.2V
LVDS Differential input Low Threshold voltage	RXVTL	-100	-	-	mV	
LVDS Differential input Common mode voltage	RXVCM	0.7	-	1.6	V	
LVDS Differential voltage	VID	200	-	600	mV	

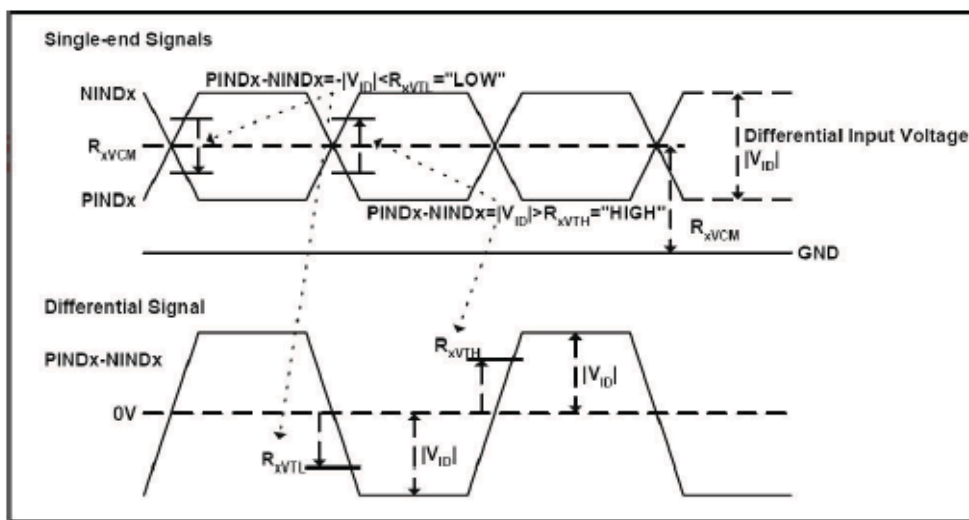

5.3.2 Timing Table

Item	Symbol	Values			Unit	Remark
		Min.	Typ.	Max.		
Clock Frequency	1/Tc	(68.9)	71.1	(73.4)	MHz	Frame rate=60Hz
Horizontal display area	tHD	1280			Tc	
HS period time	tH	(1410)	1440	(1470)	Tc	
HS Width + Back Porch + Front Porch	tHW+tHBP+tHFP	(60)	160	(190)	Tc	
Vertical display area	tVD	800			tH	
VS period time	tV	(815)	823	(833)	tH	
VS Width + Back Porch + Front Porch	tVW+tVBP+tVFP	(15)	23	(33)	tH	

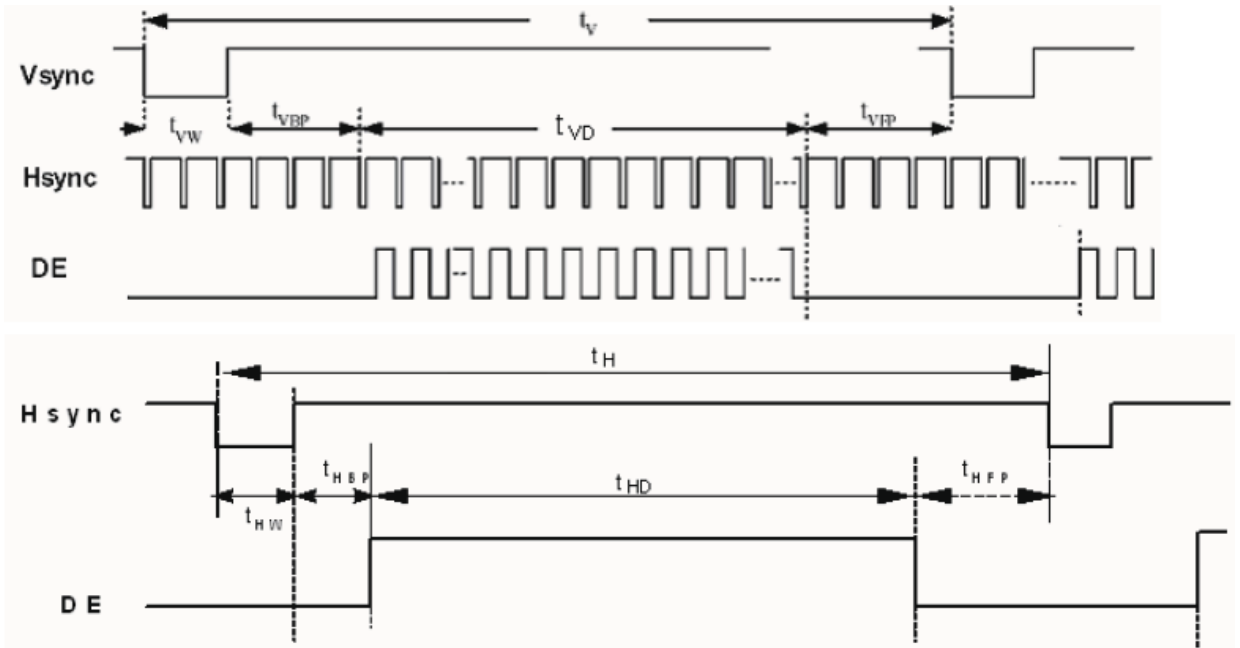

5.3.3 LVDS Data Input Format

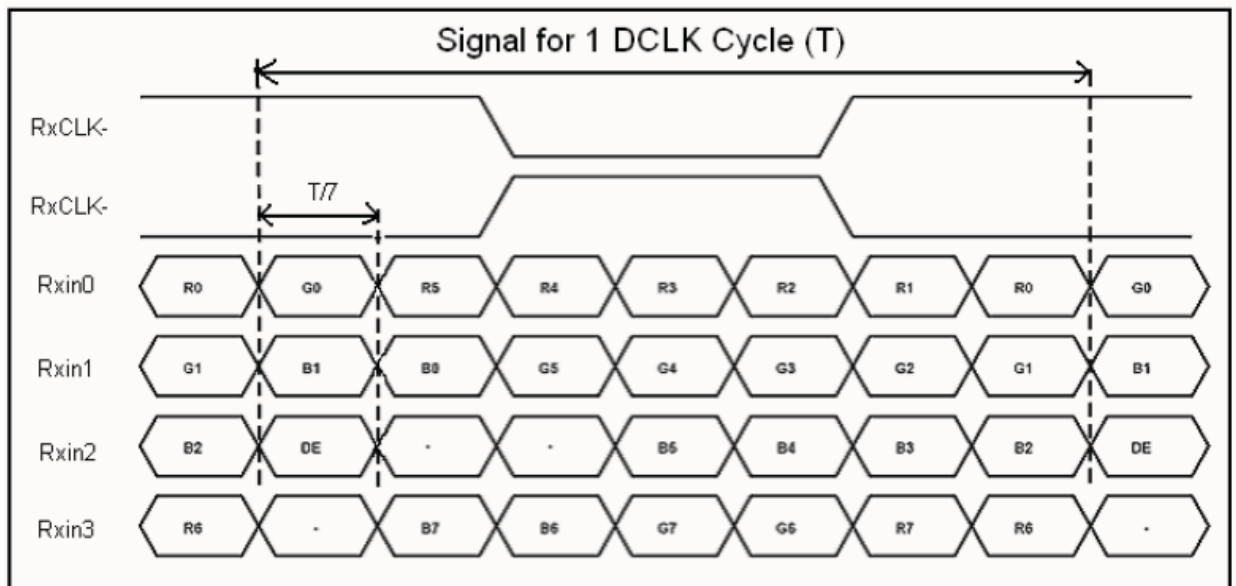

6. LCD PIN CONNECTIONS

Pin #	Signal Name	I/O	Description	Remarks
1	VDD	P	Power Supply	
2	VDD	P	Power Supply	
3	NC	--	No connection	
4	NC	--	No connection	
5	Rxin0-	I	-LVDS Differential Data Input	
6	Rxin0+	I	+LVDS Differential Data Input	
7	VSS	P	Ground	
8	Rxin1-	I	-LVDS Differential Data Input	
9	Rxin1+	I	+LVDS Differential Data Input	
10	VSS	P	Ground	
11	Rxin2-	I	-LVDS Differential Data Input	
12	Rxin2+	I	+LVDS Differential Data Input	
13	VSS	P	Ground	
14	RxCLK-	I	-LVDS Differential Clock Input	
15	RxCLK+	I	+LVDS Differential Clock Input	
16	VSS	P	Ground	
17	Rxin3-	I	-LVDS Differential Data Input	
18	Rxin3+	I	+LVDS Differential Data Input	
19	VSS	P	Ground	
20	LED_GND	P	LED Ground	
21	LED_GND	P	LED Ground	
22	LED_GND	P	LED Ground	
23	NC	--	No connection	
24	LED_PWM	I	PWM control signal of LED converter	
25	NC	--	No connection	
26	CABC_EN	I	CABC Enable Input	
27	NC	--	No connection	
28	LED_VCCS	P	LED Power	
29	LED_VCCS	P	LED Power	
30	LED_VCCS	P	LED Power	

I: input, O: output, P: Power

Note1: The setting of CABC function are as follows.

Pin	Enable	Disable
CABC_EN	High Voltage	Low Voltage or open

Note2: LED_PWM is used to adjust backlight brightness.

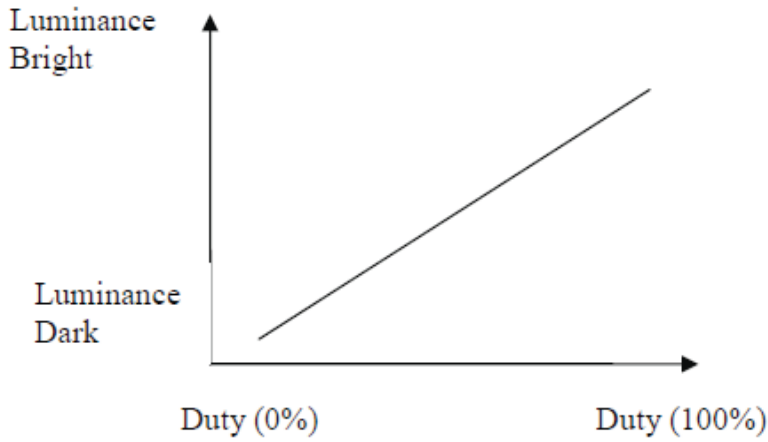

7. LCD BLOCK DIAGRAM

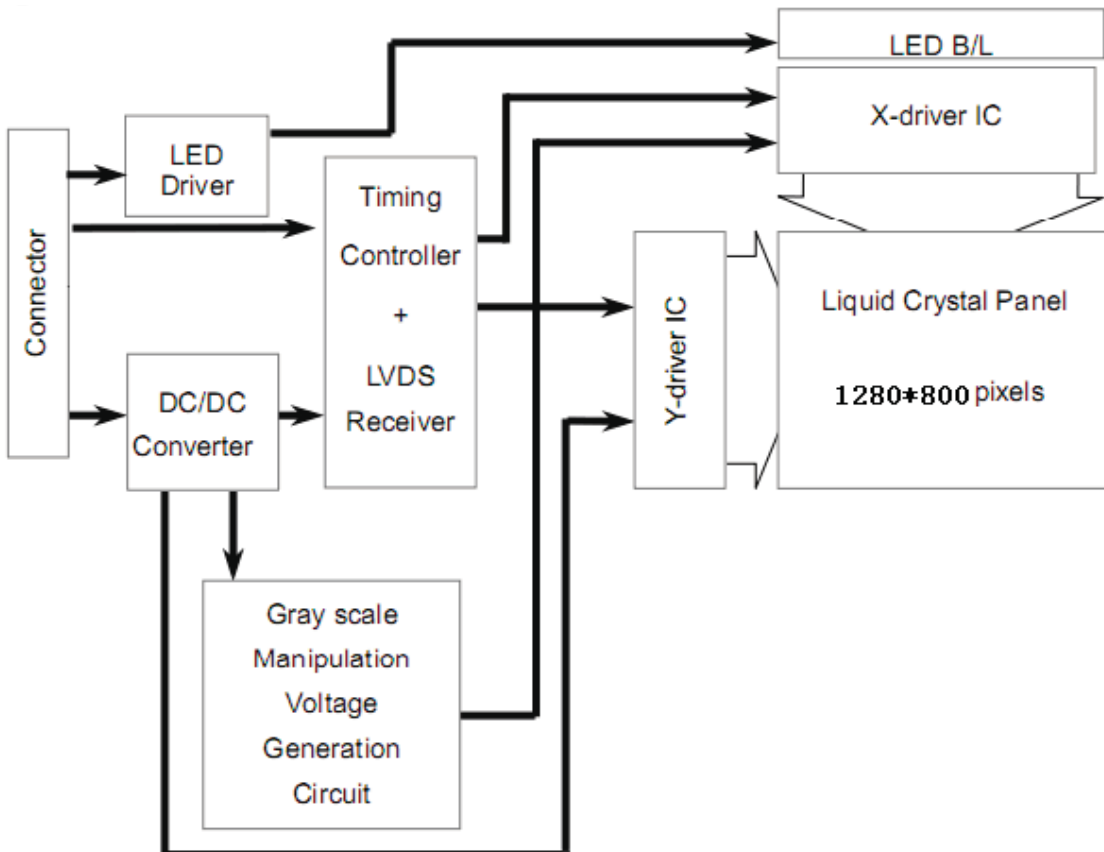

8. CTP INTERFACE AND DATA FORMAT

8.1 CTP General Specifications

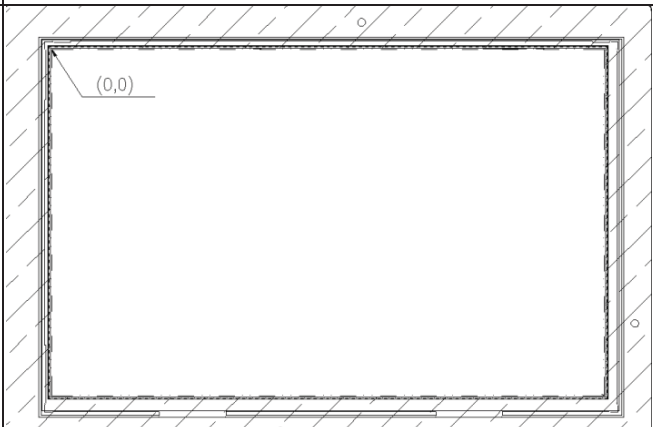
Item	Specification	Unit
Type	Transparent type projected capacitive touch panel	
Input mode	Human's finger	
Multi touch	2	Point
Interface	USB	
(X,Y) Position		

8.2 CTP Absolute Maximum Rating

Symbol	Description	Min	Typ	Max	Unit	Notes
VCC	Supply voltage	-0.3	-	6.5	V	USB 5V
Vio	DC input voltage	-0.3	-	VCC+0.3	V	

8.3 CTP DC Electrical Characteristic

Symbol	Description	Min	Typ	Max	Unit	Notes
VCC	Supply voltage	4.75	5	5.25	V	
GND	Supply voltage	-	0	-	V	
ICC	Supply current	-	70	-	mA	VCC=5V

8.4 CTP PIN CONNECTIONS

Pin Number	Pin Name	Description
1	VCC	Power Supply Voltage
2	D-	USB D-
3	D+	USB D+
4	NC	No connection
5	GND	Ground

9. OPTICAL CHARACTERISTICS

Item	Symbol	Condition	MIN.	TYP.	MAX.	Unit	Remarks
Viewing Angle (CR≥ 10)	θ_L	$\Phi=180^\circ$ (9 o'clock)	75	85	--	degree	Note 1
	θ_R	$\Phi=0^\circ$ (3 o'clock)	75	85	--		
	θ_T	$\Phi=90^\circ$ (12 o'clock)	75	85	--		
	θ_B	$\Phi=270^\circ$ (6 o'clock)	75	85	--		
Response time	T_{ON}	Normal $\theta=\Phi=0^\circ$	-	10	20	ms	Note 3
	T_{OFF}		-	15	30	ms	
Contrast ratio	CR		600	800	--	--	Note 4
Color chromaticity	W_X		0.27	0.31	0.35	--	Note2,5,6
	W_Y		0.28	0.32	0.36	--	
Luminance	L		230	290	--		Note6
Luminance uniformity	YU		70	--	--		Note7

Test Conditions:

- VDD=3.3V, LED_VCCS=5V, LED_PWM=100%Duty , CABC_EN="Low", the ambient temperature is 25°C.
- The test systems refer to Note 2.

Note 1: Definition of viewing angle range

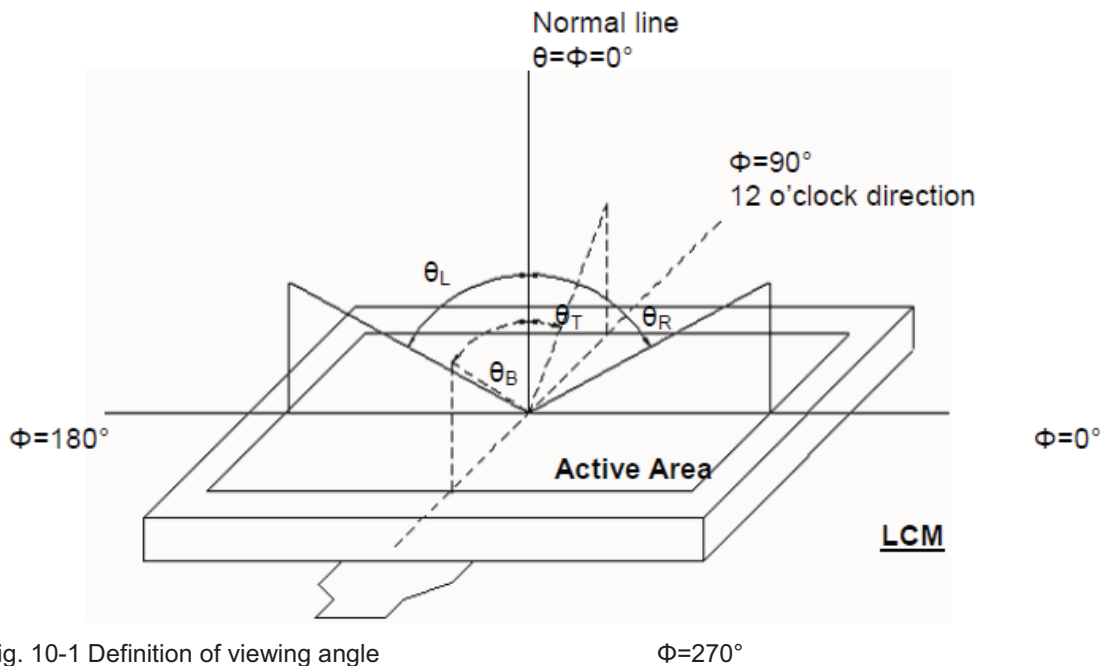

Fig. 10-1 Definition of viewing angle

Note 2: Definition of optical measurement system.

The optical characteristics should be measured in dark room. After 30 minutes operation, the optical properties are measured at the center point of the LCD screen. (Viewing angle is measured by ELDIM-EZ contrast/Height :1.2mm, Response time is measured by Photo detector TOPCON BM-7, other items are measured by BM-5A/ Field of view: 1° /Height: 500mm.)

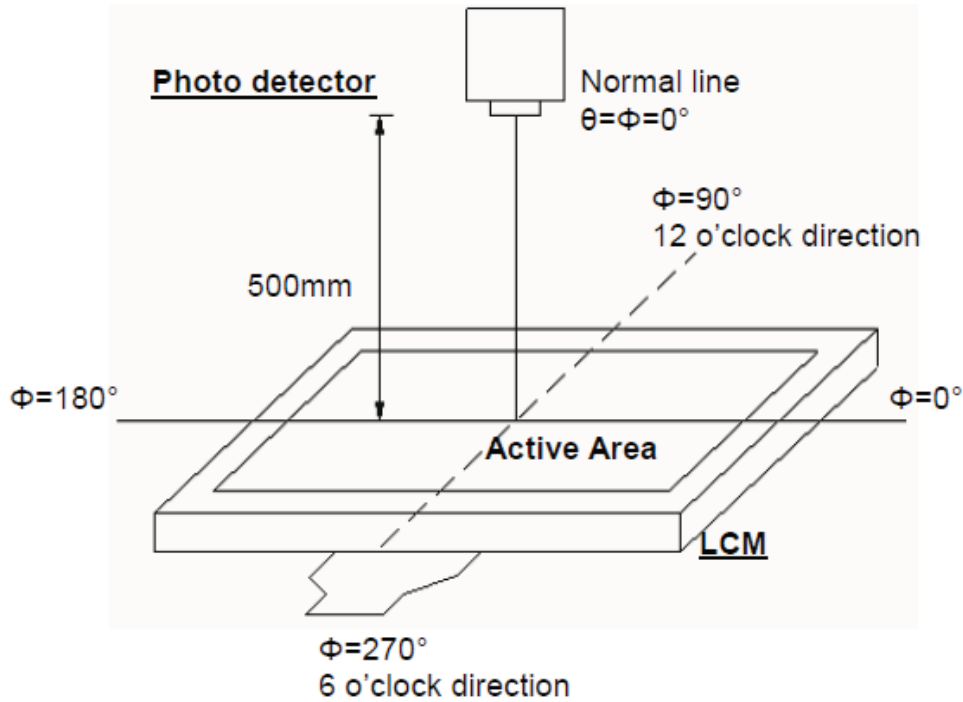

Fig. 10-2 Optical measurement system setup

Note 3: Definition of Response time

The response time is defined as the LCD optical switching time interval between "White" state and "Black" state. Rise time (T_{ON}) is the time between photo detector output intensity changed from 90% to 10%. And fall time (T_{OFF}) is the time between photo detector output intensity changed from 10% to 90%.

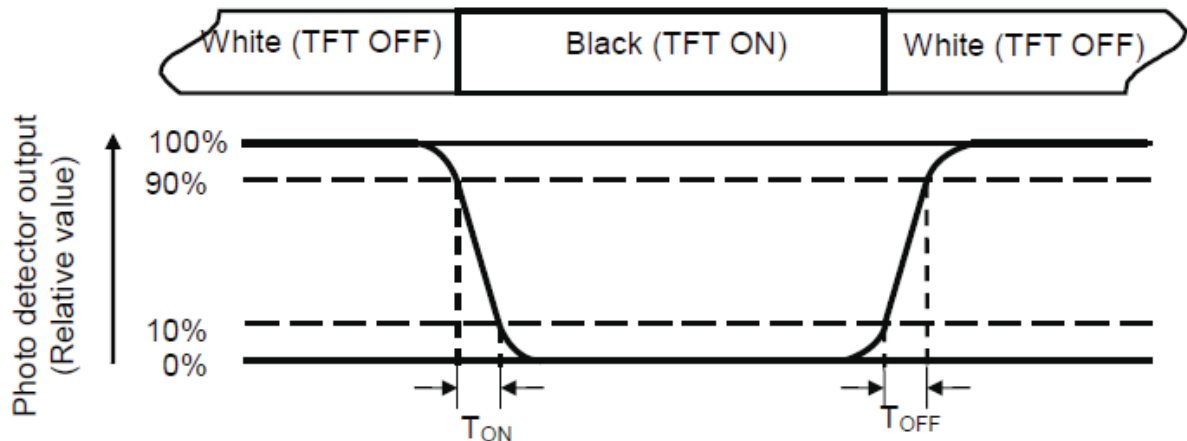

Fig. 10-3 Definition of response time



Confidential Document

Note 4: Definition of contrast ratio (CR):

$$CR = \frac{\text{Luminance with all pixels in white state}}{\text{Luminance with all pixels in Black state}}$$

Note 5: Definition of color chromaticity (CIE1931)

Color coordinates measured at center point of LCD.

Note 6: Measuring the center area of the panel.

Note 7: Definition of Brightness Uniformity (B-uni):

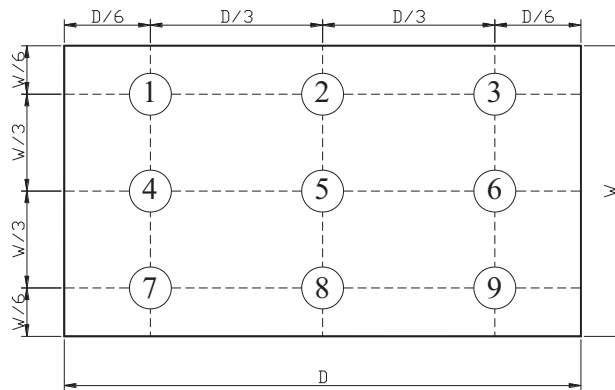

$$B\text{-uni} = \frac{\text{Minimum luminance of 9 points}}{\text{Maximum luminance of 9points}}$$

10. QUALITY ASSURANCE

10.1 Test Condition

10.1.1 Temperature and Humidity (Ambient Temperature)

Temperature : $25 \pm 5^{\circ}\text{C}$

Humidity : $65 \pm 5\%$

10.1.2 Operation

Unless specified otherwise, test will be conducted under function state.

10.1.3 Container

Unless specified otherwise, vibration test will be conducted to the product itself without putting it in a container.

10.1.4 Test Frequency

In case of related to deterioration such as shock test. It will be conducted only once.

10.1.5 Test Method

Reliability Test Item & Level		Test Level	Remark
No.	Test Item		
1	High Temperature Storage Test	T=60°C, 120hrs	IEC68-2-2
2	Low Temperature Storage Test	T=-20°C, 120hrs	IEC68-2-1
3	High Temperature Operation Test	T=50°C, 120hrs	IEC68-2-2
4	Low Temperature Operation Test	T=0°C, 120hrs	IEC68-2-1
5	High temperature and high humidity operation test	T=40°C,90%RH,120hrs	IEC68-2-3
6	Thermal cycling storage test (No operation)	-20°C ---> +25°C ---> +60°C ,100Cycle 30min 5min 30min	IEC68-2-14
7	Vibration Test (No operation)	Frequency:10~55HZ Amplitude:1.5mm Sweep time:11min Test period:6Cycles for each direction of X,Y,Z	IEC68-2-6
8	Electro Static Discharge Test	State: operating Standard: IEC 61000-4-2 Location: LCM/TP surface Condition:150pf 330Ω Contact +/- 4kV Air +/-8kV Criteria: Class	IEC-61000-4-2

10.2 Inspection condition

10.2.1 Inspection conditions

10.2.2 Inspection Distance : 30 ± 5 cm

10.2.3.1 View Angle :

(1) Inspection that light pervious to the product: $90 \pm 15^\circ$

(2) Inspection that light reflects on the product: $90 \pm 15^\circ$

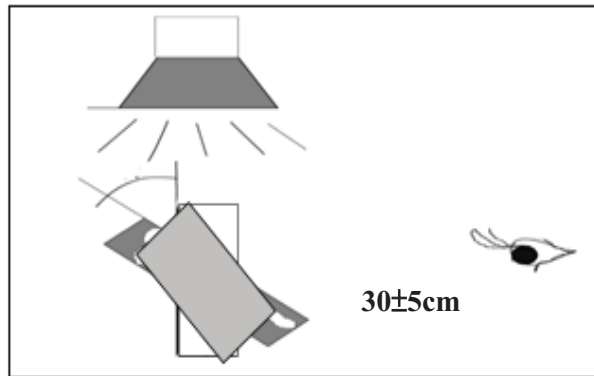
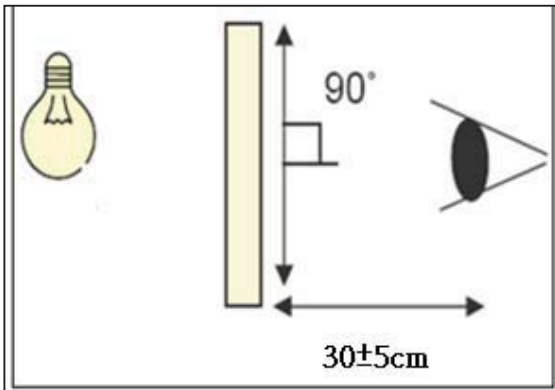

10.3 Environment conditions:

Ambient Temperature :	$25 \pm 5^\circ\text{C}$
Ambient Humidity :	30~75%RH
Ambient Illumination	600~800 lux

10.4 Inspection Parameters

Appearance inspection standard (D: diameter, L: length; W: width, Z: height, T: glass thickness)

Inspection item	Inspection standard	Description
No image	Prohibited	
Image abnormal	Prohibited	
Bright line	Prohibited	
Thin line	It is acceptable that the defect can not be seen with 2% ND filter.	
Mura	It is acceptable that the defect can not be seen with 2% ND filter.	

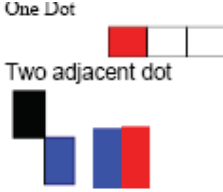
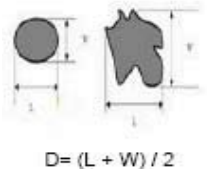
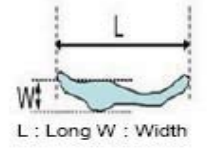
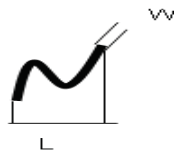
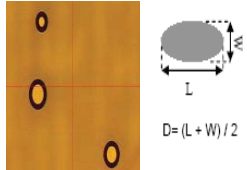
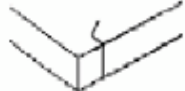
Dot	Item	Acceptable	Total	
		Visible area		
	Bright dot	3	6	
	Dark dot	5		
	Bright adjacent dots	1	1	
	Dark adjacent dots	2	2	
Adjacent dots with a bright dot and a dark dot	2	2		
Foreign material in dot shape	SPEC (unit: mm)		Acceptable	
	$D \leq 0.5$		Ignored	
	$0.5 < D \leq 0.8$, distance > 5		$n \leq 5$	
	$D > 0.8$		0	
Foreign material in line shape	SPEC		Acceptable	
	$W \leq 0.05$ and $L \leq 10$		Ignored	
	$0.05 < W \leq 0.1$, $L \leq 10$, distance > 5		$n \leq 5$	
	$W > 0.1$ or $L > 10$		0	
Polarizer flaw or leak out resin	Defect is defined as the active area.			
Contamination	It is acceptable if the dirt can be wiped.			
Scratch	SPEC		Acceptable	
	$W \leq 0.05$ and $L \leq 10$		Ignored	
	$0.05 < W \leq 0.08$, $L \leq 10$, distance > 5		$n \leq 5$	
	$0.08 < W \leq 0.1$, $L \leq 10$, distance > 5		$n \leq 3$	
	$W > 0.1$ or $L > 10$		0	
Bubble	SPEC (unit: mm)		Acceptable	
	$D \leq 0.3$		Ignored	
	Non visible area		Ignored	
	$0.3 < D \leq 0.5$, distance > 5		$n \leq 5$	
	$D > 0.5$		0	
Cover & Sensor Crack	Prohibited			

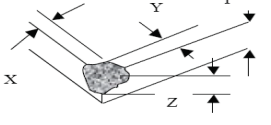
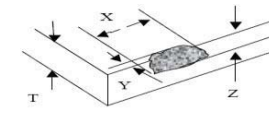
Cover angle missing	SPEC (unit: mm)	Acceptable	
	Side/Bottom	Ignored	
	It is prohibited if the defect appears on the front.	0	
Cover edge break	SPEC (unit: mm)	Acceptable	
	$X \leq 3.0, Y \leq 3.0, Z \leq T$	Ignored	
	$X > 3.0, Y > 3.0, Z > T$	0	
Ink	SPEC (unit: mm)	Acceptable	
	word unclear, inverted, mistake, break line	0	
Bubble under protection film	SPEC (unit: mm)	Acceptable	
	NA		
Function	Prohibited		

10.5 Sampling Condition

Unless otherwise agree in written, the sampling inspection shall be applied to the incoming inspection of customer.

Lot size: Quantity of shipment lot per model.

Sampling type: normal inspection, single sampling

Sampling table: MIL-STD-105E

Inspection level: Level II

Class of defects	Definition		
	Major	AQL 0.65%	It is a defect that is likely to result in failure or to reduce materially the usability of the product for the intended function.
	Minor	AQL 1.5%	It is a defect that will not result in functioning problem with deviation classified.

11. LCM PRODUCT LABEL DEFINE

Product Label style:



Bar Code Define:

AA6001421026-0013

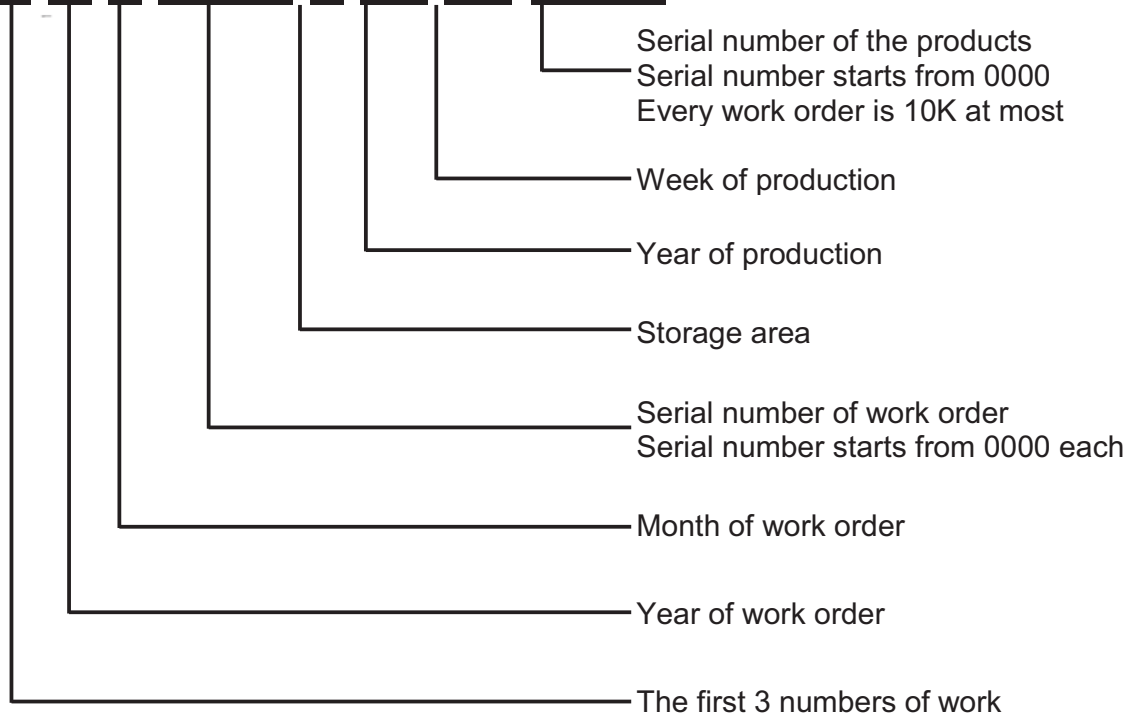



Confidential Document

Product Name Define:

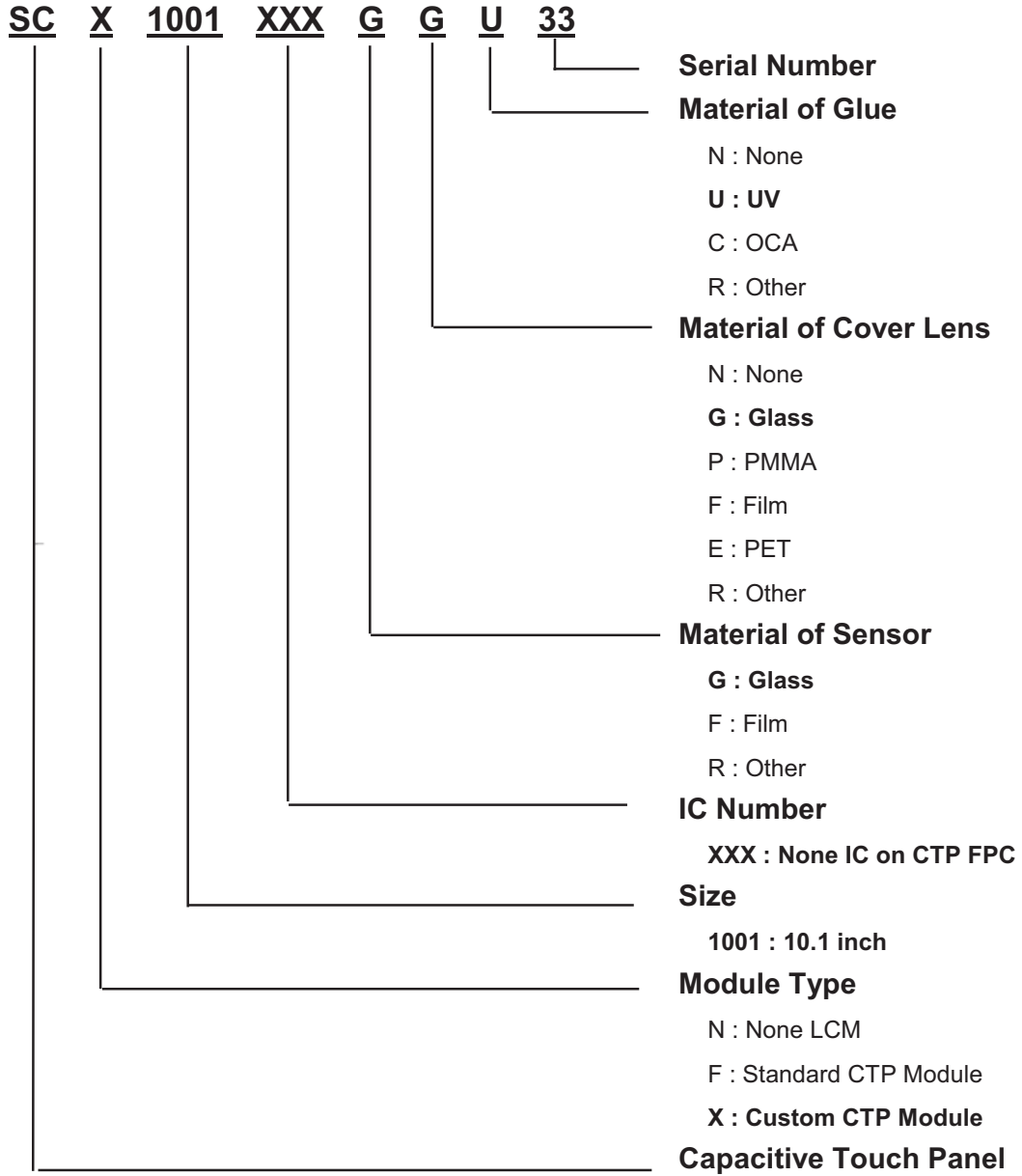



Confidential Document

12. PRECAUTIONS IN USE LCM

1. ASSEMBLY PRECAUTIONS

- (1) Since Touch Panel is consist of glass, please be careful your hands to be injured during handing. You must wear gloves during handing.
- (2) Do not touch, push or rub the exposed touch panel, tweezers or anything harder than HB pencil lead. And please do not rub with dust clothes with chemical treatment.
- (3) Do not stack the touch panels together. Do not put heavy objects on touch panel.
- (4) Please do not take a CTP to pieces and reconstruct it. Resolving and reconstructing modules may cause them not to work well.
- (5) Please excessive force or strain to the panel or tail is prohibited, Do not lift touch panel by cable (FPC).
- (6) Use clean sacks or glove to prevent fingerprints and/or stains left on the panel. Extra attention and carefulness should be taken while handling the glass edge.
- (7) Please pay attention for the matters stated below at mounting design of touch panel enclosure.
Enclosure support to fix touch panel must be out of active area.(do not design enclosure presses the active area to protect from miss put)

2. OPERATING PRECAUTIONS

- (1) Please be sure to turn off the power supply before connecting and disconnecting signal input cable.
- (2) Please do not change variable resistance settings in CTP. They are adjusted to the most suitable value. If they are changed, it might happen CTP does not satisfy the characteristics specification
- (3) Be careful for condensation at sudden temperature change. Condensation makes damage to sensor or electrical contacted parts.
- (4) CTP has high frequency circuits. Sufficient suppression to the electromagnetic interference shall be done by system manufacturers. Grounding and shielding methods may be important to minimize the interference.
- (5) Touch the panel with your finger or stylus only to assure normal operation. Any sharp edged or hard objects are prohibited.
- (6) Operate the panel in a steady environment. Abrupt variation on temperature and humidity may cause malfunction of the panel.

3. ELECTROSTATIC DISCHARGE CONTROL

- (1) The operator should be grounded whenever he/she comes into contact with the CTP. Never touch any of the conductive parts such the copper leads on the FPC and the interface terminals with any parts of the human body.

- (2) The CTP should be kept in antistatic bags or other containers resistant to static for storage.
- (3) Only properly grounded soldering irons should be used.
- (4) If an electric screwdriver is used, it should be well grounded and shielded from commentator sparks.
- (5) The normal static prevention measures should be observed for work clothes and working benches; for the latter conductive (rubber) mat is recommended
- (6) Since dry air is inductive to statics, a relative humidity of 50-60% is recommended.

4. STORAGE PRECAUTIONS

- (1) When you store touch panel for a long time, it is recommended to keep the temperature between 0°C-40°C without the exposure of sunlight and to keep the humidity less than 90%RH.
- (2) Please do not leave touch panel in the environment of high humidity and high temperature such as 60°C 90%RH
- (3) Please do not leave touch panel in the environment of low temperature; below -20°C.

5. OTHERS

For the packaging box, please pay attention to the followings:

- a. Please do not pile them up more than 5 boxes. (They are not designed so.) And please do not turn over.
- b. Please handle packaging box with care not to give them sudden shock and vibrations. And also please do not throw them up.
- c. Packing box and inner case for CTP are made of cardboard. So please pay attention not to get them wet. (Such like keeping them in high humidity or wet place can occur getting them wet.)

6. LIMITED WARRANTY

Unless otherwise agreed between DATA IMAGE and customer, DATA IMAGE will replace or repair any of its CTP which is found to be defective electrically and visually when inspected in accordance with DATA IMAGE acceptance standards, for a period on one year from date of shipment. Confirmation of such date shall be based on freight documents. The warranty liability of DATA IMAGE is limited to repair and/or replacement on the terms set forth above. DATA IMAGE will not responsible for any subsequent or consequential events.

Confidential Document
13. OUTLINE DRAWING

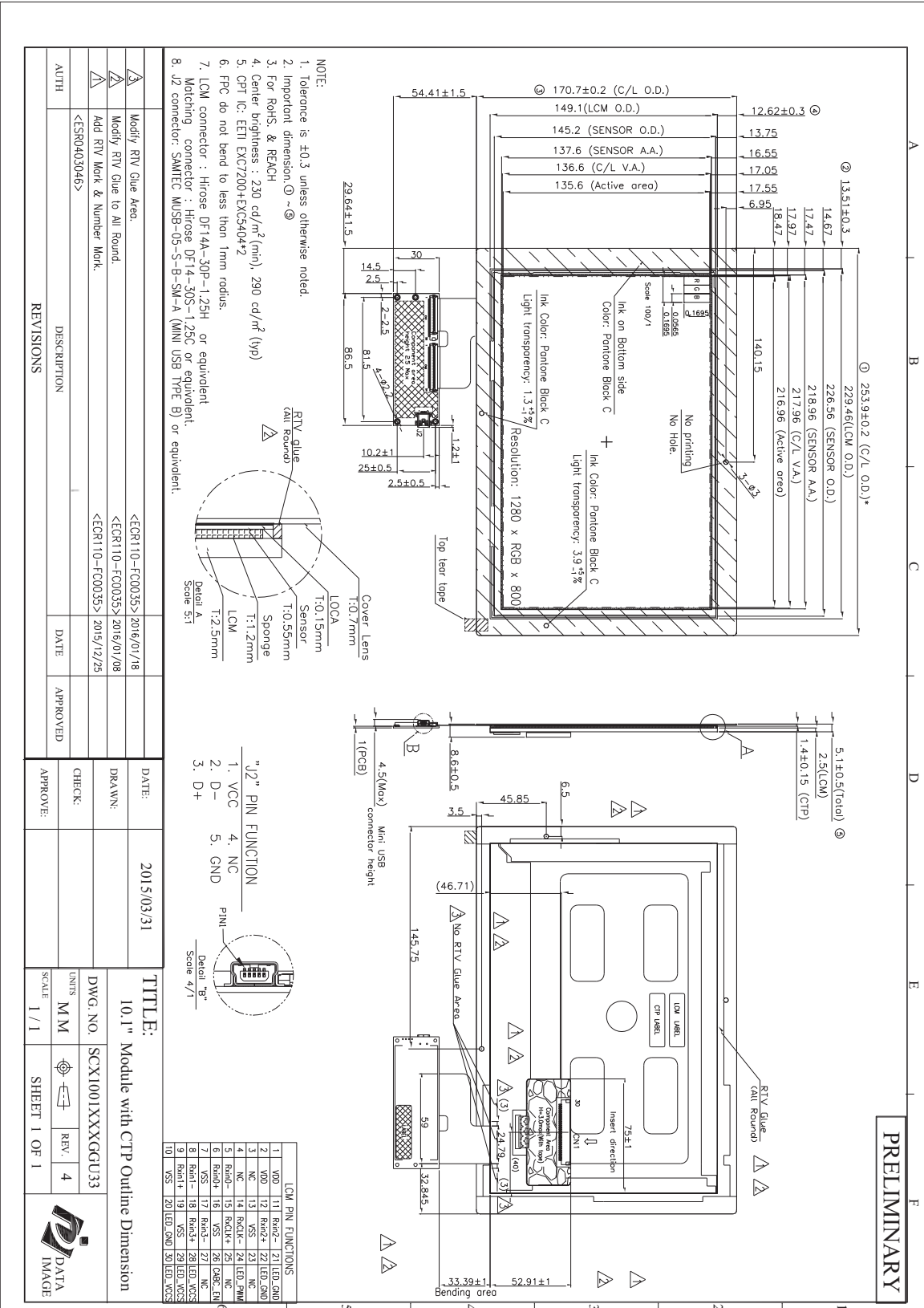



Confidential Document

14. PACKAGE INFORMATION

TBD